

EXPLOSION PROOF IN-LINE FLAME ARRESTER

**PROSAVE
FLAME ARRESTER**

FA TYPE



Benefits

- Meet the latest international rule requirement of API 2000 and EN 12874
- Protection against explosion and deflagration flame
- High flow capacity and minimum pressure loss
- Available bi-directional flow and flame passage
- Available vertical and horizontal installation
- Very easy maintenance for quick cleaning
- High performance chemical resistance material

General

The flame arrester is designed to prevent flame transmission when flammable gas/air- or vapor/air-mixtures are present.

The model FA in-line flame arrester is designed, manufactured and tested according to API 2000 and EN 12874.

Body material of arrester is available for nodular cast iron, cast steel, stainless steel grade 304, 316, 316L and special alloy steel for chemical resistance.

The material of element is available for stainless steel grade 316L or special alloy steel for chemical resistance.

The flame element is constructed with crimped ribbon metal.

Specification of gas/air-mixtures for deflagration and detonation tests(EN12874:2001)

Range of Application (Marking)		Requirement for test mixture	
Explosion group	MESG of mixture (mm)	Gas type	Gas in air by volume(%)
IIA	> 0.90	Propane	4.2 ± 0.2
IIB1	≥0.85	Ethylene	5.0 ± 0.1
IIB2	≥0.75		5.5 ± 0.1
IIB3	≥0.65		6.5 ± 0.5
IIB	≥0.50	Hydorgen	45.0 ± 0.5
IIC	< 0.50	Hydorgen	28.5.2 ± 2.0

MESG : Maximum Experimental Safe Gap

EXPLOSION PROOF IN-LINE FLAME ARRESTER

PROSAVE
FLAME ARRESTER

FA TYPE

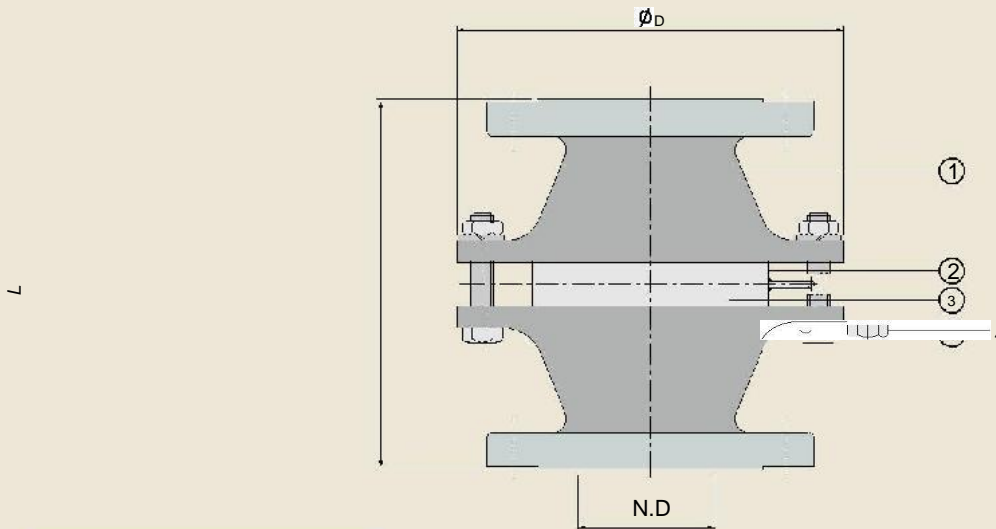

Dimension Table

Unit = mm

TYPE	FA-1	FA-1 1/2	FA-2	FA-3	FA-4	FA-5	FA-6	FA-8	FA-10	FA-12	FA-14	FA-16	FA-18	FA-20	FA-22	FA-24
SIZE	25A	40A	50A	80A	100A	125A	150A	200A	250A	300A	350A	400A	450A	500A	550A	600A
N.D	25	40	50	80	100	125	150	200	250	300	350	400	450	500	250	250
ØD	155	210	220	250	280	340	380	455	605	680	950	1150	1150	1300	1300	1500
L	225	230	230	250	260	290	320	340	365	450	650	720	720	850	850	1000
W.T(kg)	12	14	16	20	27	36	46	85	125	150	180	220	270	280	330	340

Materials of Construction

NO	DESCRIPTION	SPEC. 1	SPEC. 2	SPEC. 3
1	BODY	Carbon Steel	Stainless Steel 304	Stainless Steel 316/316L
2	ELEMENT RING	Stainless Steel 304	Stainless Steel 304	Stainless Steel 316/316L
3	ELEMENT	Stainless Steel 304	Stainless Steel 304	Stainless Steel 316/316L
4	BOLT/NUT	Stainless Steel 304	Stainless Steel 304	Stainless Steel 316

* Other material is available on special request by customers